



Characterization of a Novel, Mid-Cost Device for Ambient Monitoring of Ultrafine Particles

Una Trivanovic, Kevin Auderset, Florian Hüwe, and Konstantina Vasilatou

Federal Institute of Metrology METAS



MI-TRAP
Transport • Health • Data

ETH Nanoparticle Conference, Zürich, June 2, 2026

Motivation

- Transport related air pollution remains an important problem in Europe despite progress
- The recent revision to the European Air Quality Directive requires the measurement of ultrafine particle (UFP) number down to 10 nm
- Currently, ambient measurements are not synchronized with tail pipe measurements (i.e. measurement of particle mass vs number)
- The Mitigating Transportation Related Air Pollution (MI-TRAP) consortium aims to address this



MI-TRAP

Transport ◦ Health ◦ Data

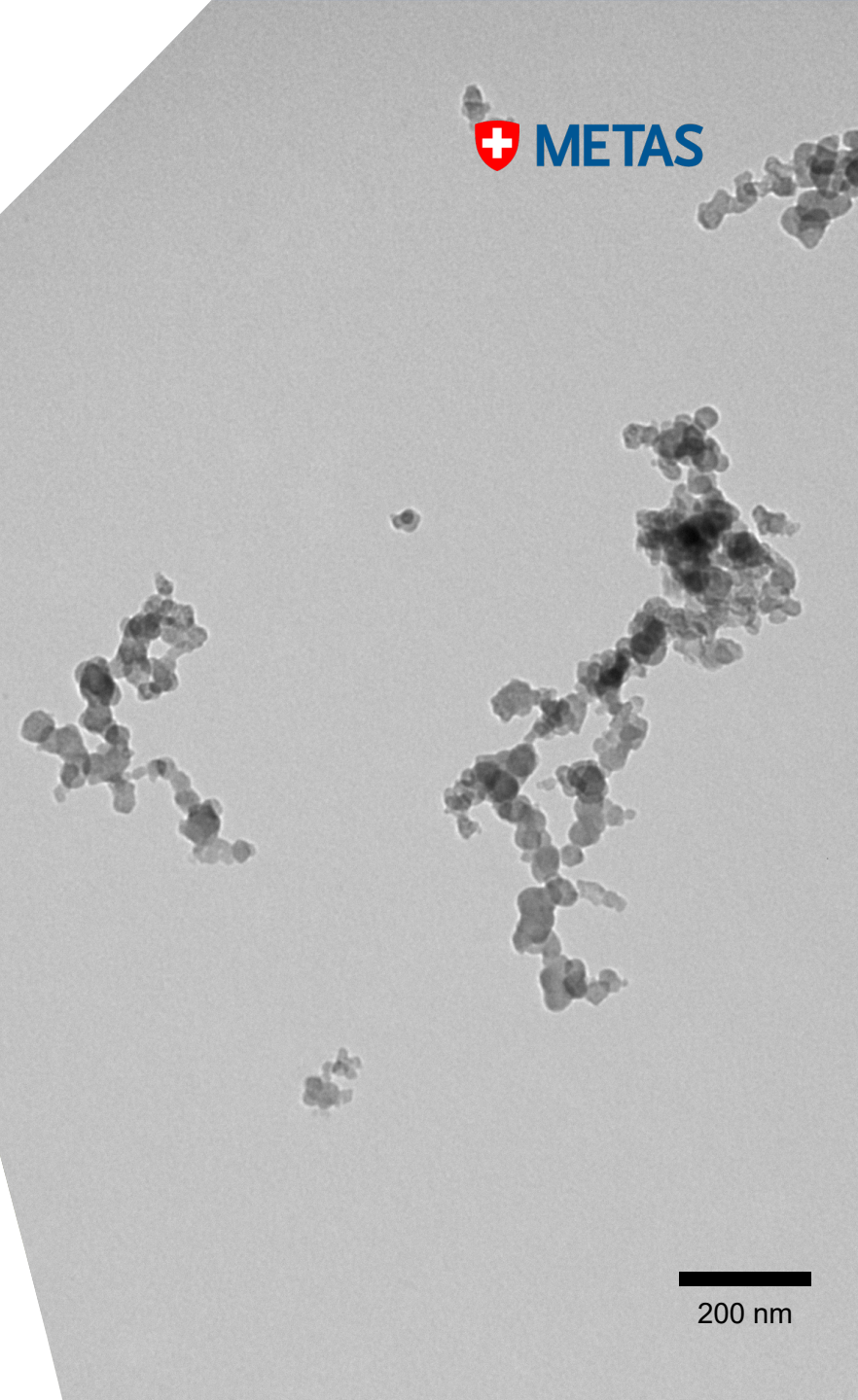

200 nm

MI-TRAP project overview



- Horizon Europe project with partners from 11 different countries aiming to improve urban air quality.

Objectives:

1. **Bridging Gaps:** Addressing disparities between transport emission standards and ambient air quality limit values
2. **Real-time Monitoring:** Enabling dynamic traffic/port/air/rail management through real-time air quality monitoring
3. **Supporting Reduction Plans:** Backing emissions and noise reduction plans
4. **Ready-to-Use Technologies:** Establishing innovative tools and solutions
 - Ultrafine particles down to 10 nm as mandated by the latest European air quality directive
5. **Citizen Engagement:** Enforcing the zero pollution strategy by engaging citizens through a citizen science methodology as part of open science practices

Air quality monitoring of particulate matter



Currently:

- Primarily mass concentration measured (PM_{2.5} and PM₁₀)
- 24-hour time resolution, insufficient to capture traffic variability
- Ultrafine particles (< 100 nm) have negligible mass and are overlooked in mass-based metrics
- Insufficient information to perform source apportionment

MI-TRAP Goals:

- Measure particle number down to 10 nm
- Measure solid particle number (sPN) in addition to total PN (tPN)
 - This harmonizes ambient measurements with tailpipe emissions regulations
 - Measuring particles with and without the volatile components provides more information for source apportionment
- Near real-time measurements will allow for cross-referencing with near real-time traffic data

Development of a mid-cost particle counter

1. Sampling & Dilution

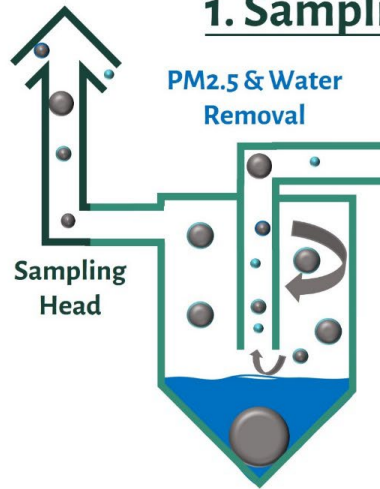

MI-TRAP

Transport • Health • Data



NANODUST

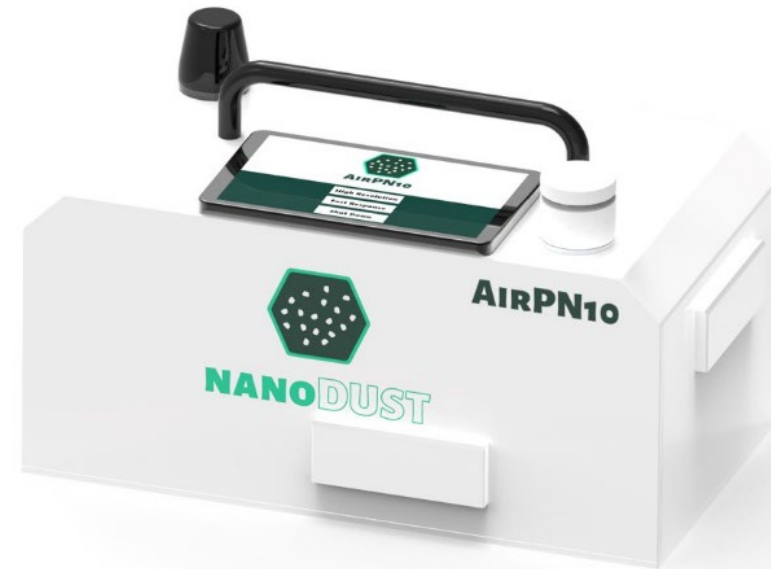

Calibration of particle counters

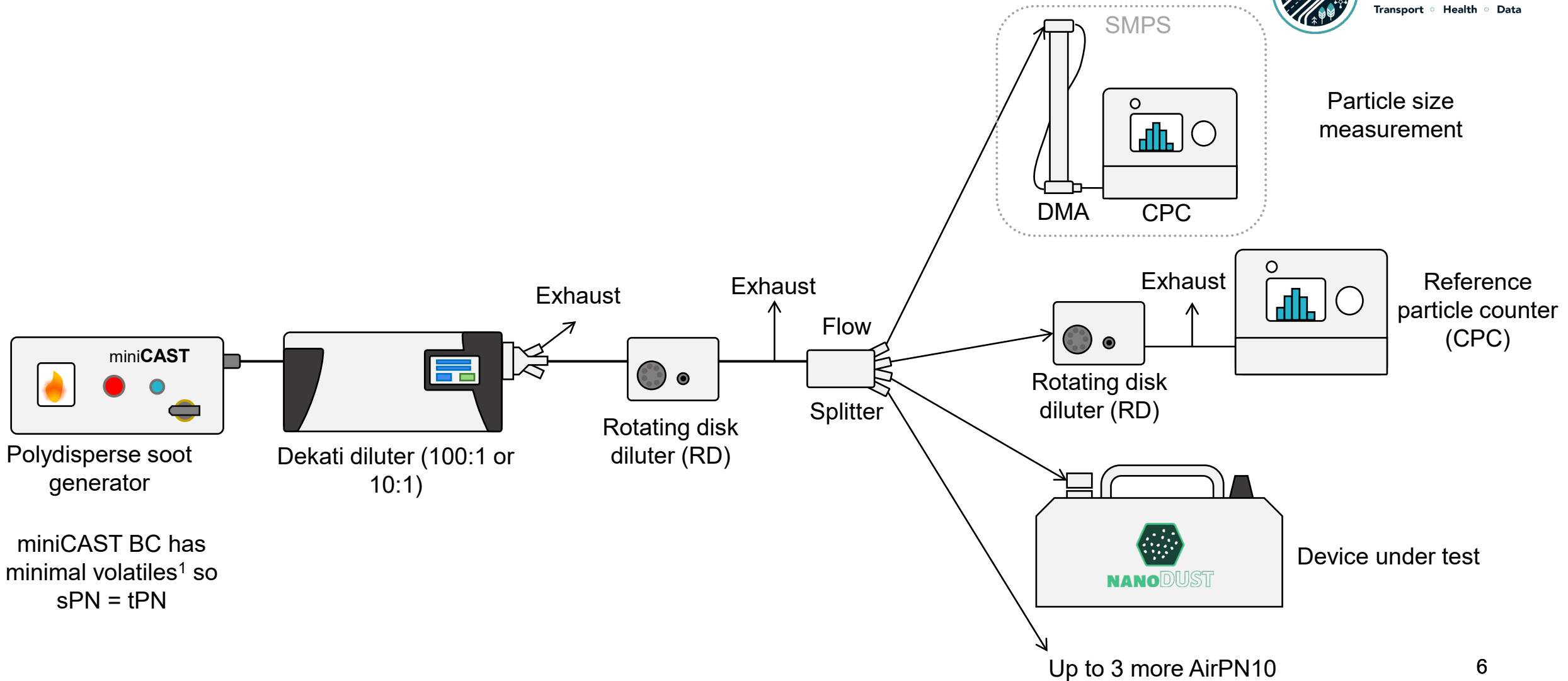

[1] Ess & Vasilatou (2018) *Aerosol Sci. Technol.* 53, 29-44. doi: 10.1080/02786826.2018.1536818

Particle size distributions

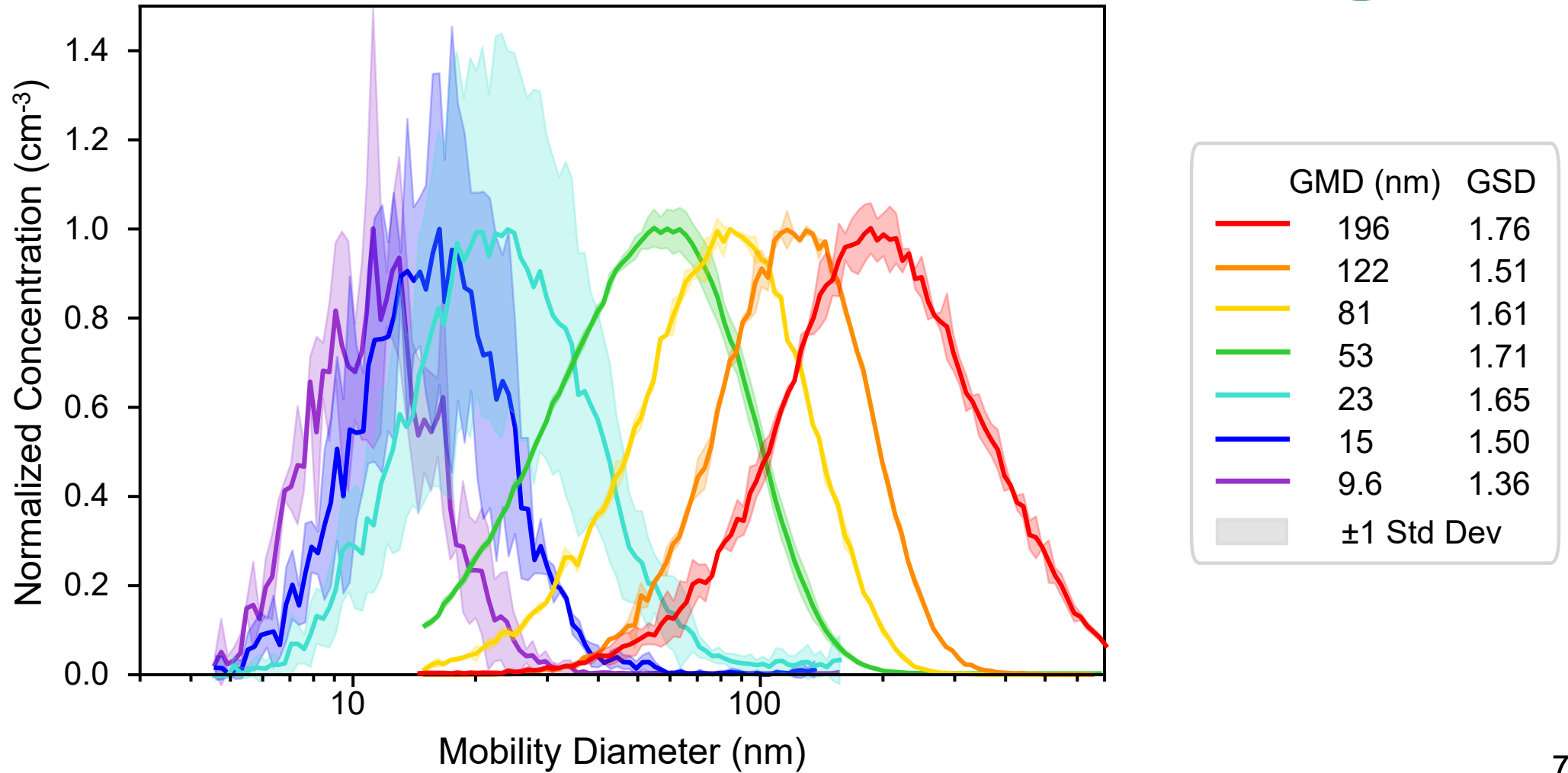

AirPN10 Size Estimate

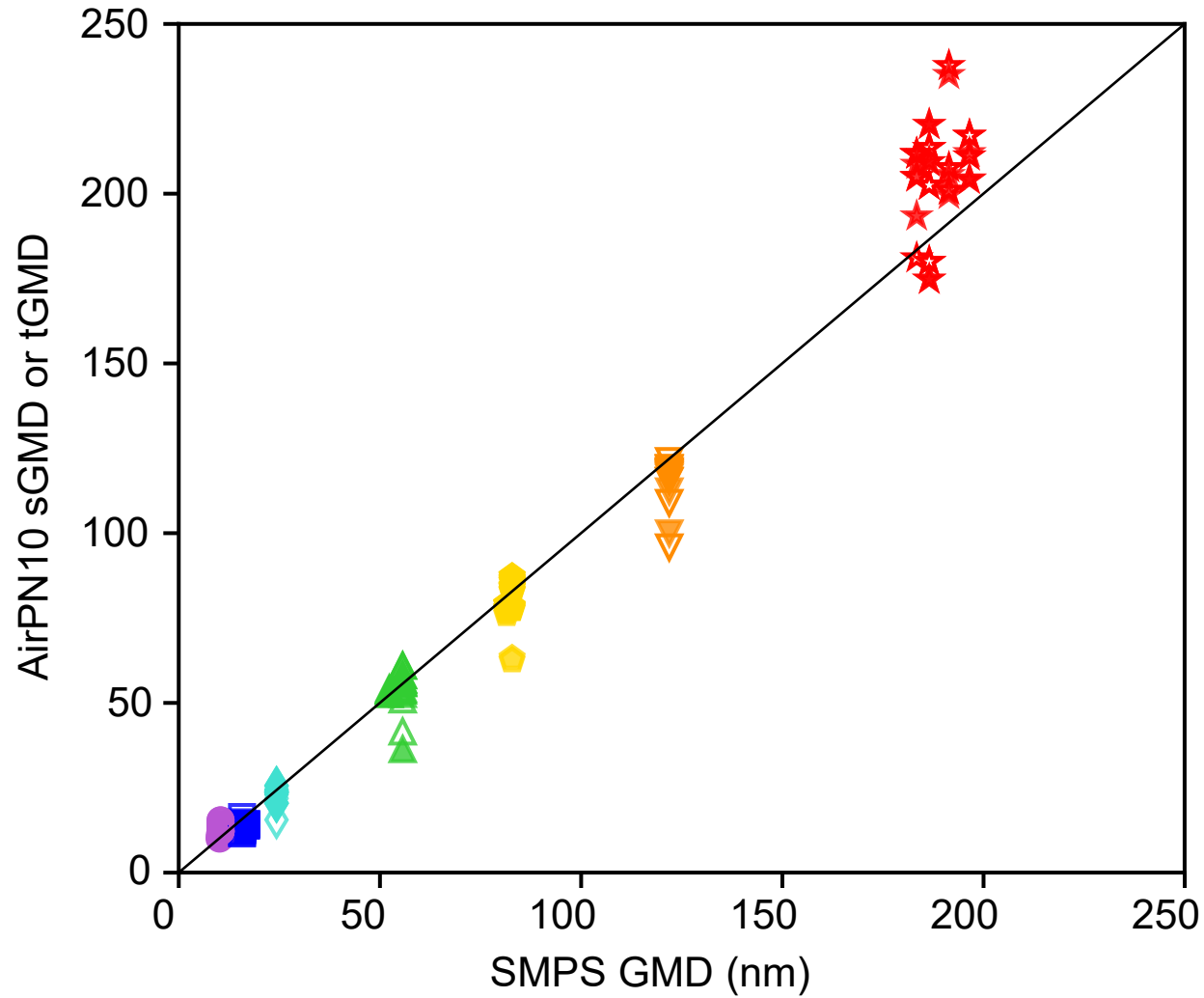

sPN	tPN	Size (nm)
★	★	200 nm
▽	▽	120 nm
⬠	⬠	80 nm
▲	▲	50 nm
◆	◆	23 nm
■	■	15 nm
●	●	10 nm

AirPN10 characterization



MI-TRAP
Transport • Health • Data

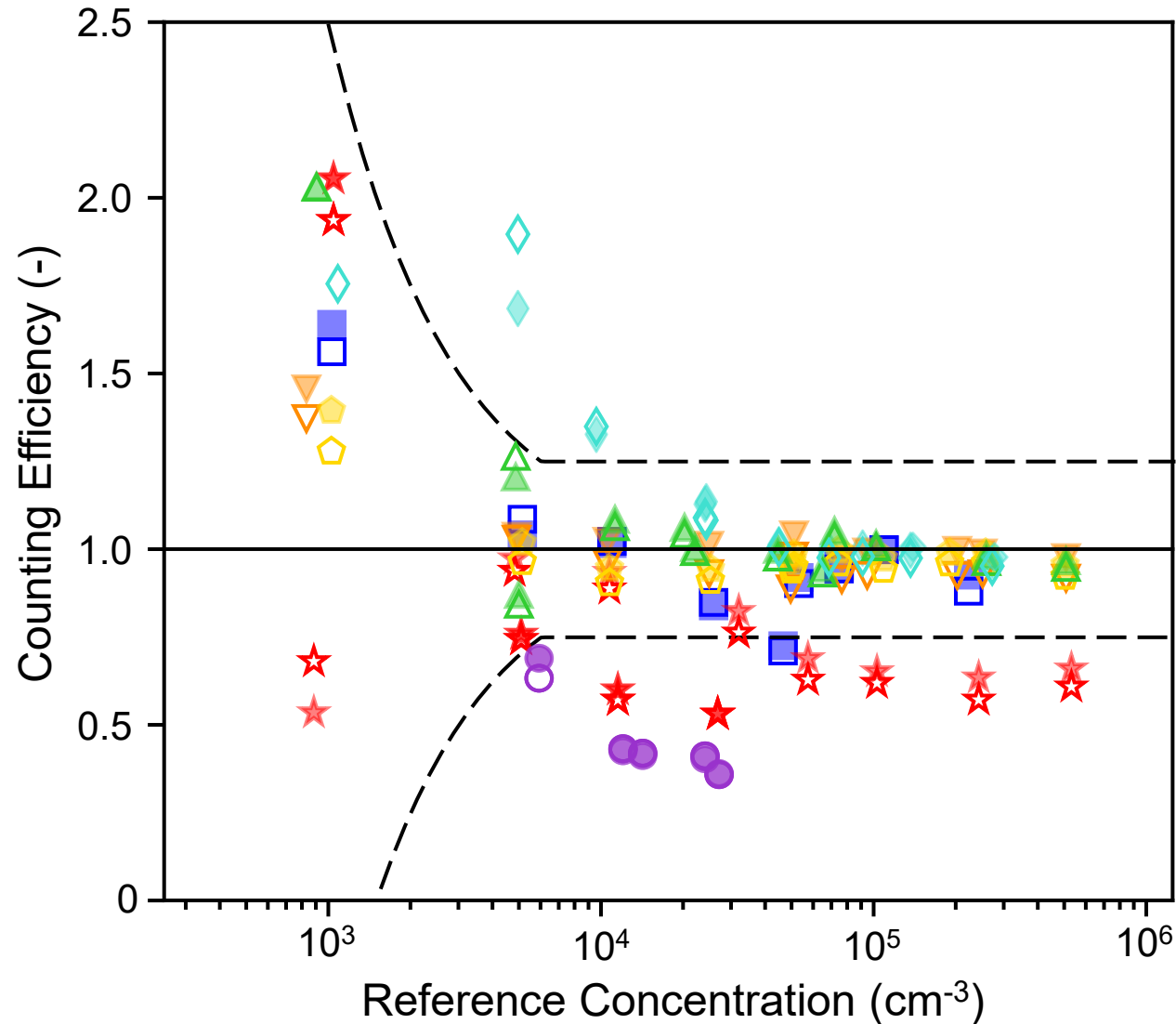

sPN tPN

- ○ 10 nm
- □ 15 nm
- ◆ ◇ 23 nm
- ▲ △ 50 nm
- ⬠ ⬡ 80 nm
- ▽ ▼ 120 nm
- ★ ☆ 200 nm

--- Larger of ± 25% or 1500 cm⁻³

AirPN10 Uncertainty Analysis

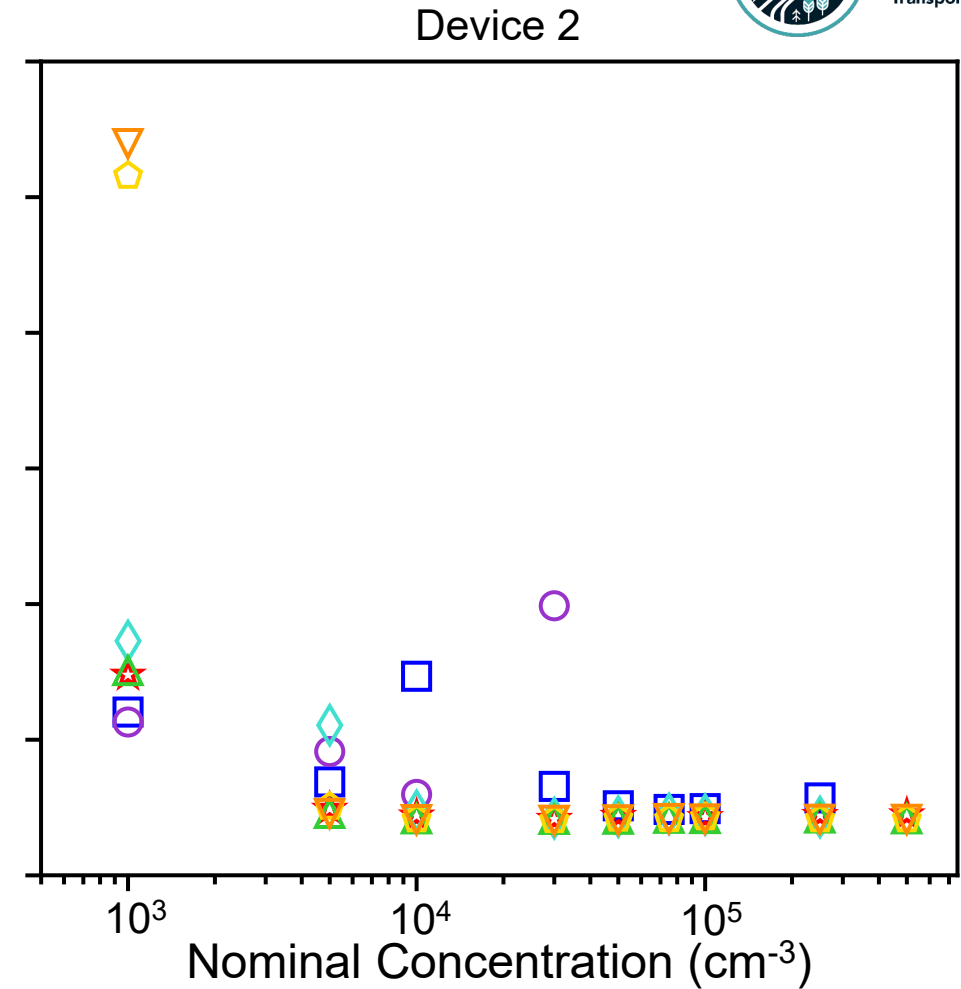
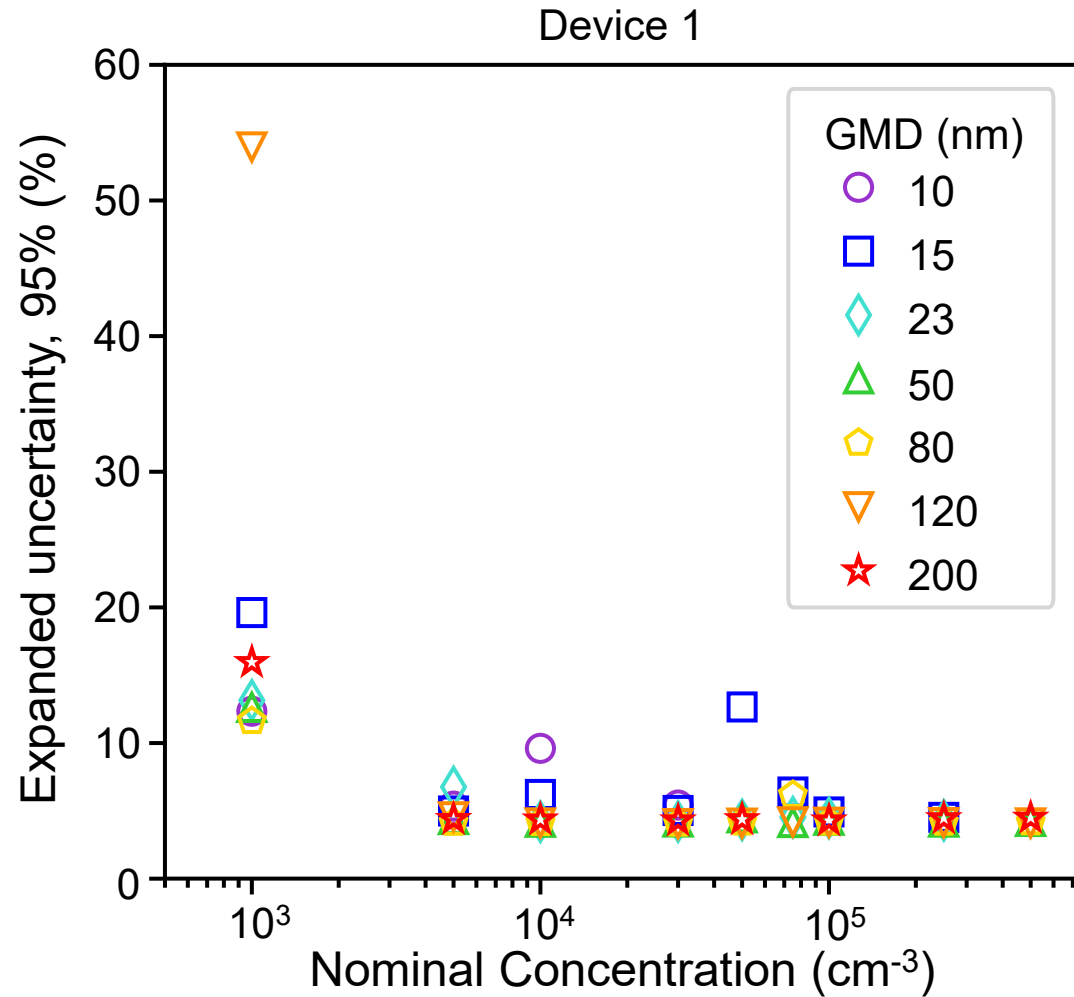

AirPN10 – ambient testing

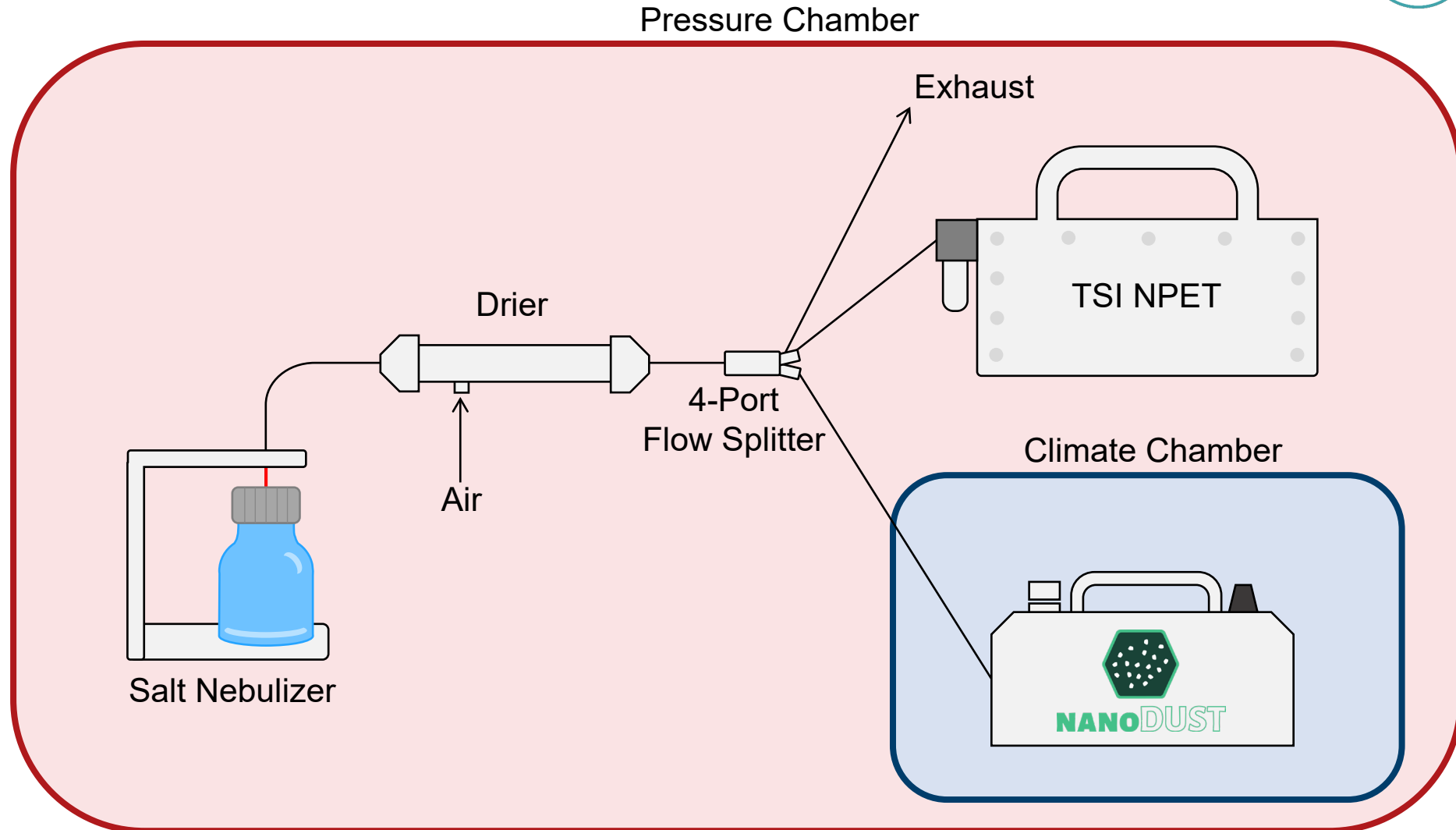

AirPN10 – ambient testing

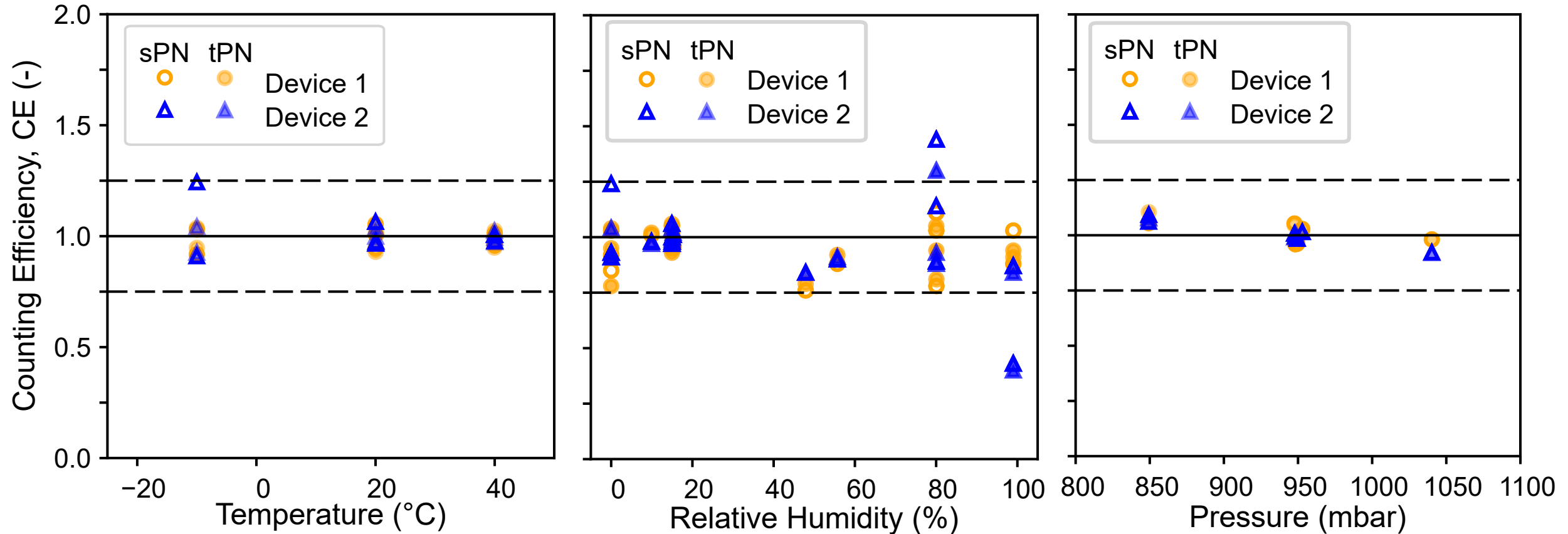

Volatile Particle Remover Test

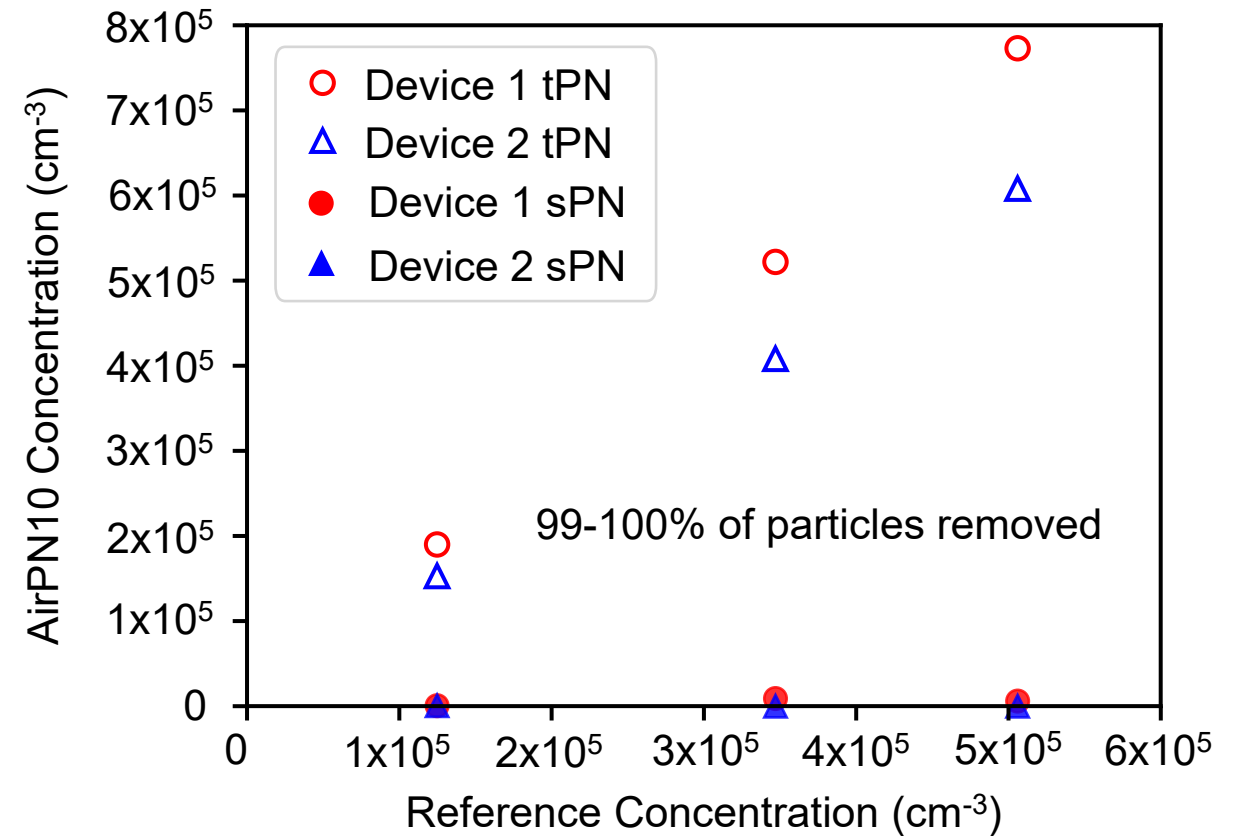
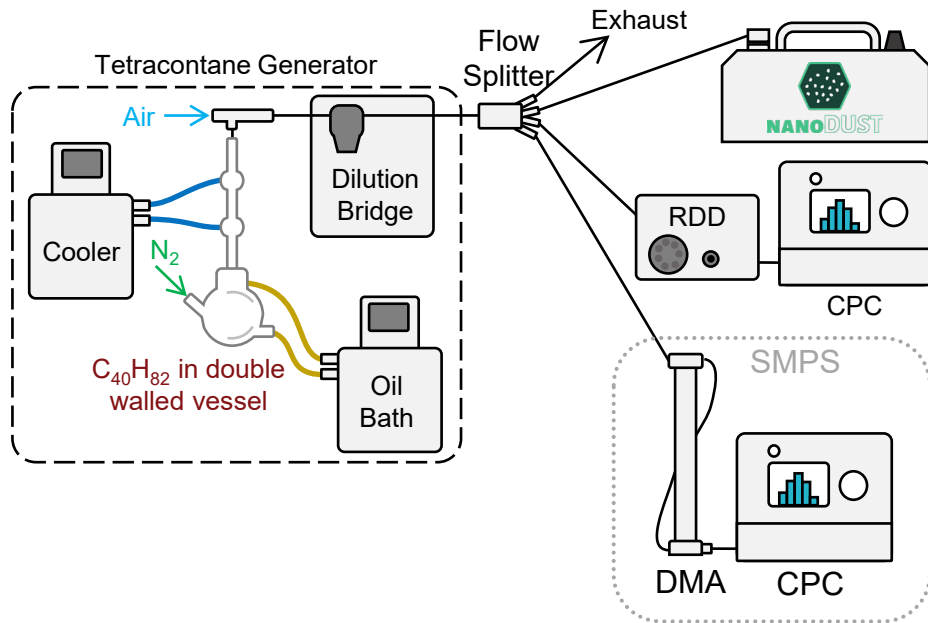

Future work: VPR to be tested with ambient-like particles

MI-TRAP pilot cities



MI-TRAP
Transport • Health • Data



- Technologies developed in the project will be tested for 3 months at a time in 10 cities
- Each city will have high-resolution, state-of-the-art instruments as well as cost-effective and portable devices

View inside cost-effective MI-TRAP box



Summary



- MI-TRAP aims to improve air quality monitoring and bridge the gap between tail pipe emissions and ambient air quality measurements
- New technologies such as mid-cost devices capable of monitoring solid and total particle number down to 10nm are being developed
- These technologies are currently being deployed in 10 pilot cities across Europe
- At the end of the project, the tools developed will be available online to aid policy-makers and other stakeholders understand the impact of transport on air quality and human health

Thank you for your attention

More information at mitrap-project.eu

una.trivanovic@metas.ch

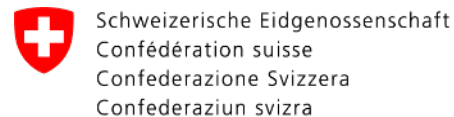

Eidgenössisches Institut für Metrologie METAS



MI-TRAP
Transport • Health • Data



Funded by
the European Union